

# INSTALLATION INSTRUCTIONS

## CAT 928/IT28 G WHEEL LOADER



HAMMOND AIR CONDITIONING LTD  
INGERSOLL, ONT.  
1-800-267-2665  
1-888-267-3745 (FAX)

## **CAT 928G INSTRUCTIONS**

### **EVAPORATOR COIL:**

The evaporator coil goes under the driver's seat in the existing heater box. Depending on the particular machine the hose knockouts in the back of the heater/evaporator assembly and the drain knockouts in the bottom of the assembly may or may not be present.

- 1) Remove the drivers seat.
- 2) Remove all bolts for the horizontal flange of the heater box.
- 3) Remove the bolts from the vertical surface if the right hand side of the heater box.
- 4) Disconnect the heater control cables
- 5) Remove the lid of the box.

For equipment with no knockouts present, follow the instructions 6) through 8). For equipment with the knockouts present, go to step 9).

- 6) On the rear panel of the box, mark the location of the holes to be drilled for the bulkhead fittings. It will be easiest to do this with the evaporator coil and hose assembly set in place as shown in the picture below. Drill the holes using the appropriate hole saw for each.
- 7) Directly under the evaporator assembly mark and drill two holes for the copper drain tube extensions included in the kit. Drill one hole toward either end of the evaporator assembly. After drilling the holes, it will be necessary to 'dimple' the area to allow the top flange of the drain tube extension to sit flush with the bottom of the pan area. This can be accomplished by gently tapping with a ball peen hammer.
- 8) Affix the drain tube extensions into place with a silicone or epoxy adhesive. Allow to cure before getting wet.
- 9) Set the evaporator assembly into place on the existing posts (present on the machines with knockouts) or screw the bottom brackets down to the base of the pan with the self-drilling screws provided. Bolt the evaporator coil assembly into place behind the heater coil.
- 10) Insert the thermostat probe into the coil and route out through the right hand side of the box and up to the blower switch area.
- 11) Once the 5/16" and 5/8" hose have been attached to the bulkheads the box can be reassembled.

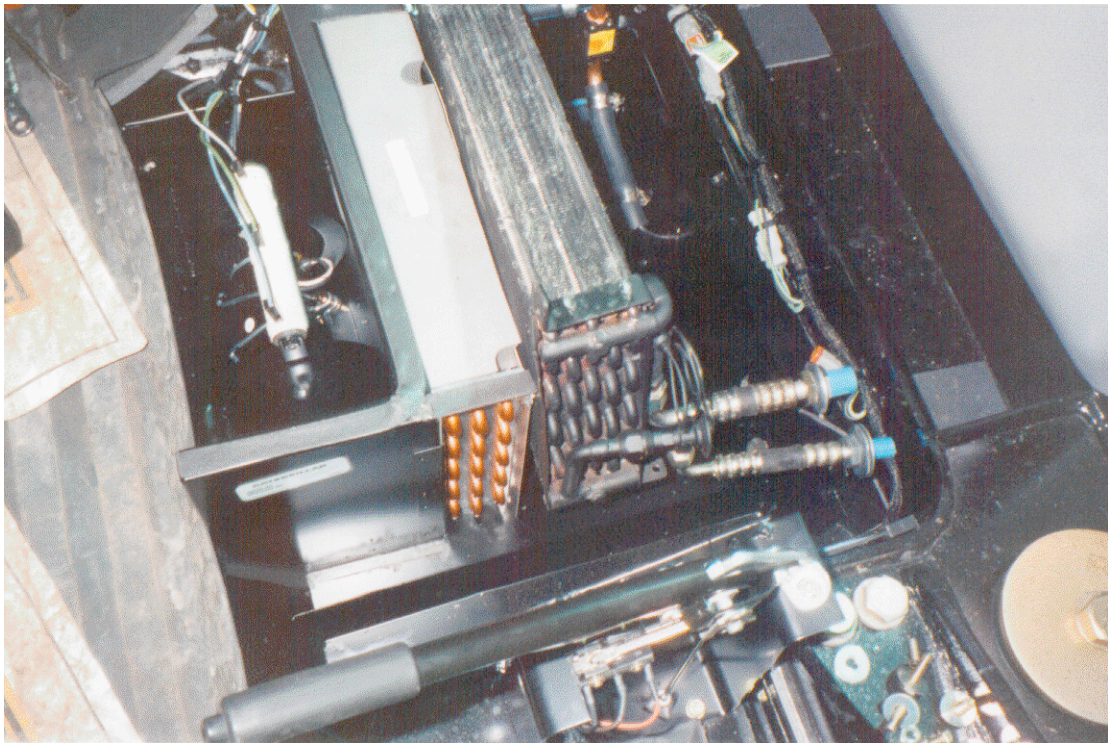

Evaporator in place alongside heater assembly.

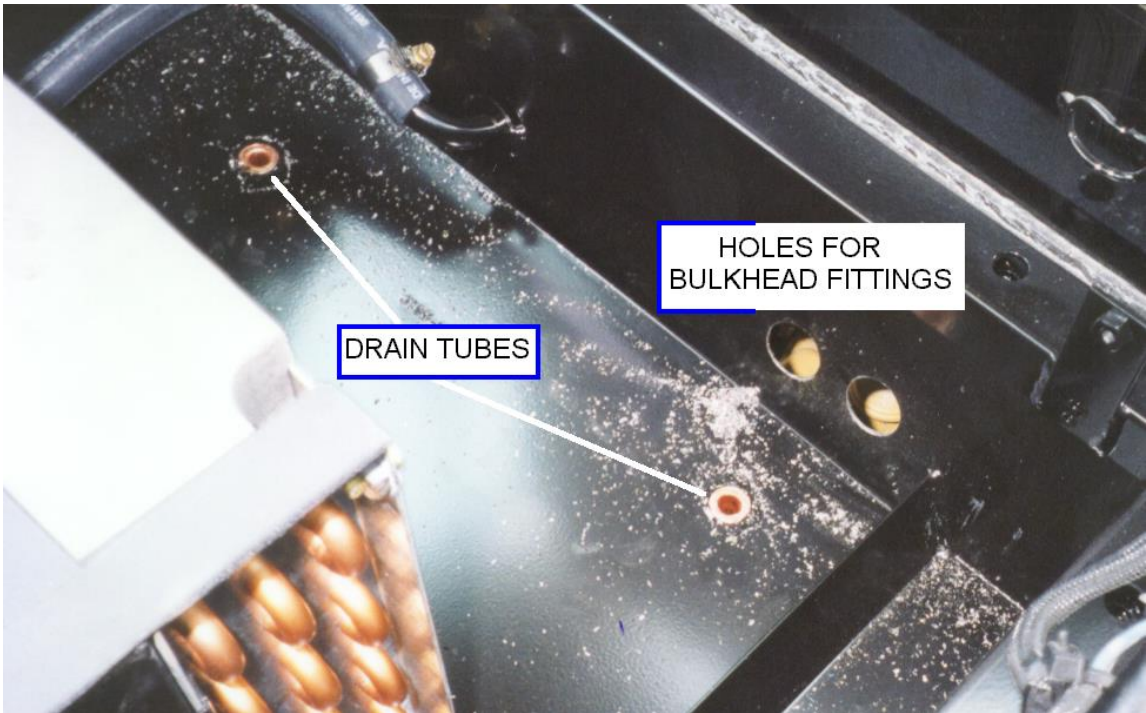

View showing drain tubes and holes for bulkhead fittings in place.

## COMPRESSOR:

The compressor mounts on the right hand side of the engine and drives off of an open pulley on the crankshaft. The compressor mount bolts on the factory mount point just ahead of the injector pump.

- 1) Install the compressor mount. Use the hardware provided in the kit.
- 2) Install the compressor onto the mount.
- 3) Install belt and tighten.

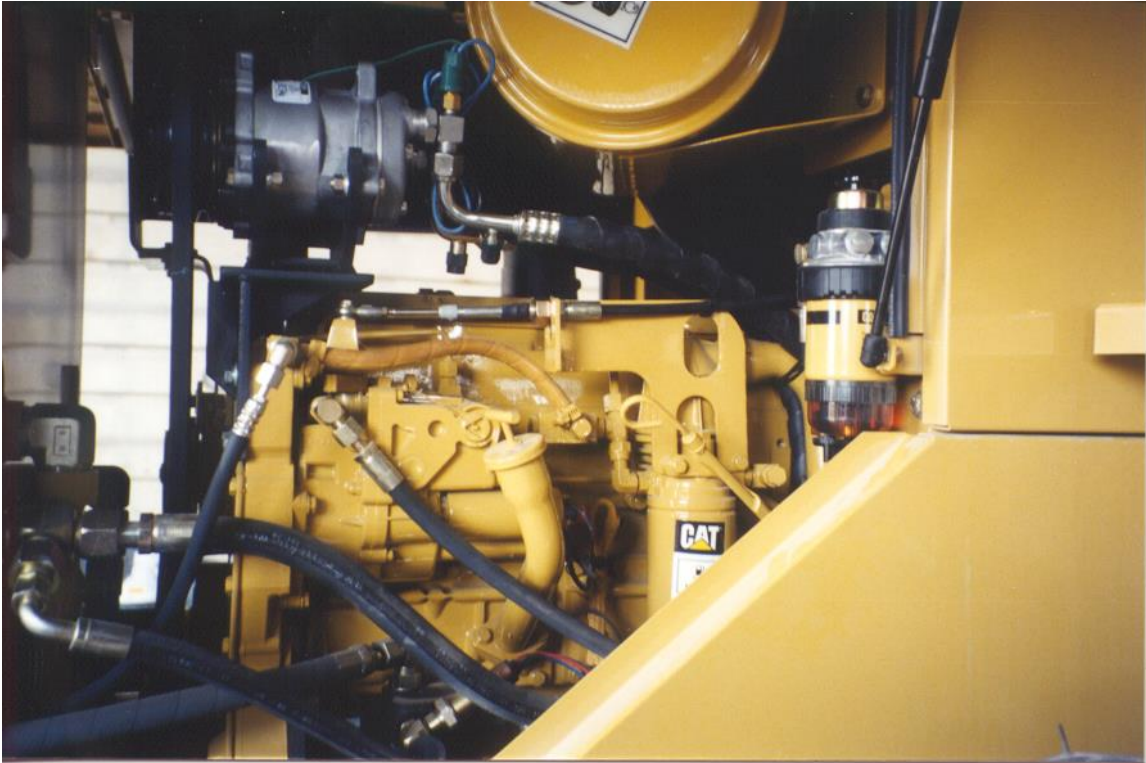

Compressor in place showing line runs.

## CONDENSER:

The condenser mounts across the face of the rad just above the oil cooler.

- 1) Slide the condenser and frame in across the face of the rad above the oil cooler.
- 2) Mark the four mounting holes on the flange of the rad frame and drill 3/16" holes.
- 3) Tap to take 1/4" 20NC thread. Because of the thickness of the rad frame, it may be desirable to use nuts on the back of the frame for the bolts to ensure they stay in place.
- 4) Bolt the condenser assembly to the rad frame using the 1/4" x 1" bolts provided in the kit.

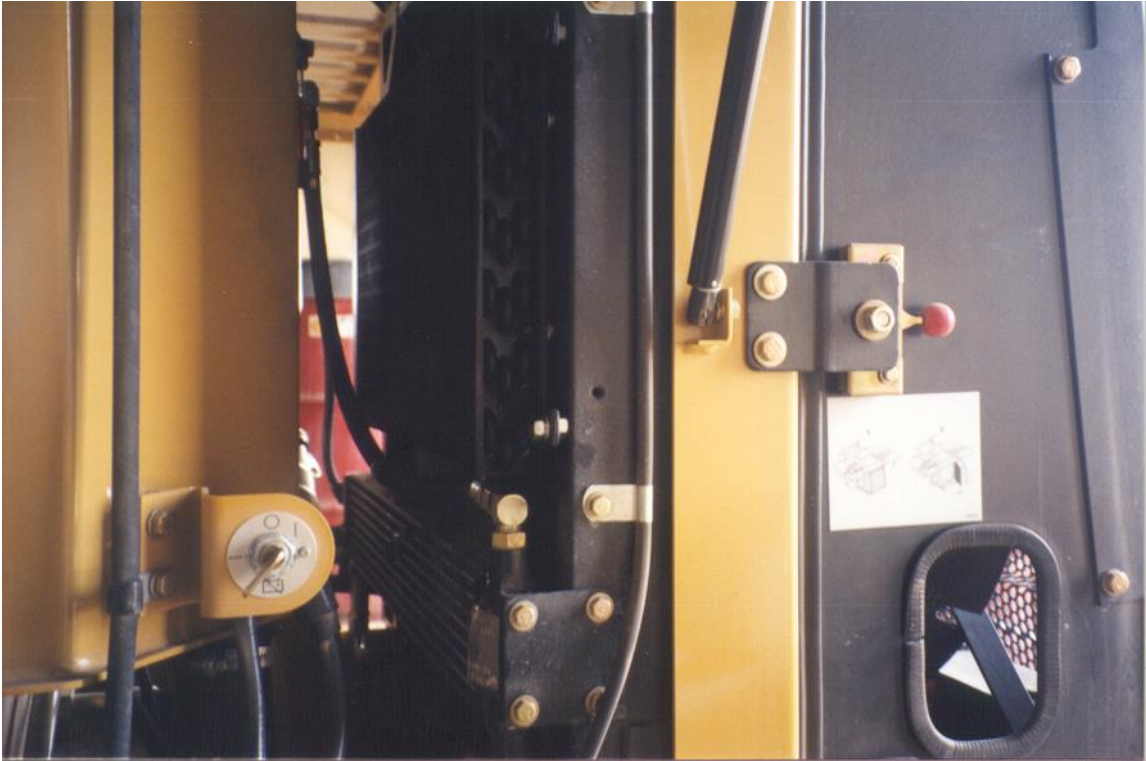

View showing left side of condenser. Front of loader to left.



Right side of condenser showing relative positions.

## **DRIER:**

The drier mounts to a stud in the main frame member on the right side of the machine. The stud is down low beside the engine and may have some other clamps on it already.

Once the straight drier bracket is mounted using the drier is secured to the bracket using the two #48 gear clamps provided. Ensure that the inlet side is orientated towards the rear of the machine.

HOSE RUNS: All the hose fittings have been pre-assembled and tested for leaks.

5/16" hose condenser to drier:

Connect the straight fitting to the lower fitting on the condenser. Route the hose up and around with the 13/32" hose, on the top fitting of the condenser, and forward toward the cab. Connect the 90o fitting on the other end of the hose to the 'INLET' fitting on the drier.

5/16" hose drier to bulkhead fitting:

Connect the 90o fitting on the hose to the 'OUTLET' fitting on the drier. Route the hose forward toward the cab along with the 13/32" hose from the compressor. Run forward along the frame to the point where the suction line meets up returning from the cab. Route the rest of the way forward with the suction hose and connect to the expansion valve on the evaporator in the evaporator box.

13/32" hose compressor to condenser:

Connect the 90o fitting with the 134a charging port up to the rotolock fitting on the discharge side of the compressor. Route the hose forward on the engine beyond the filter arrangement and then down to the frame with the suction hose. When the suction line runs forward to the cab, pick up the 5/16" hose and follow to the condenser. Connect to the top fitting on the condenser.

5/8" hose compressor to bulkhead fitting:

Connect the 90o fitting with the 134a charging port up to the rotolock fitting on the suction side of the compressor. Route the hose down to the frame (with the 13/32" hose) and back along with the 5/16" hose to the evaporator assembly. Connect to the 1/2" fitting on the evaporator coil.

**NOTES:**

1. Use the hosewrap provided to protect hoses in areas that they may pinch or chafe.
2. Secure the hoses with the cable ties and clamps provided to prevent chafing.
3. Use refrigerant oil on all O-rings and sealing surfaces.





Hose going to back of the cab. Bulkhead fittings are no longer used.

## ELECTRICAL:

Mount the thermostat on the control panel somewhere near the blower switch. Find the clutch wire running off the blower switch and cut the wire out of the bundle with enough length to reach the thermostat terminal. Crimp on a female spade connector and install the wire to the thermostat. Connect the 14ga black clutch wire to the other terminal on the thermostat and route it down out of the electrical compartment and along with the 5/8" hose. At the pressure switch, connect the clutch wire to one side of the pressure switch. Connect the other side to the clutch wire on the compressor using a male and female spade connector.

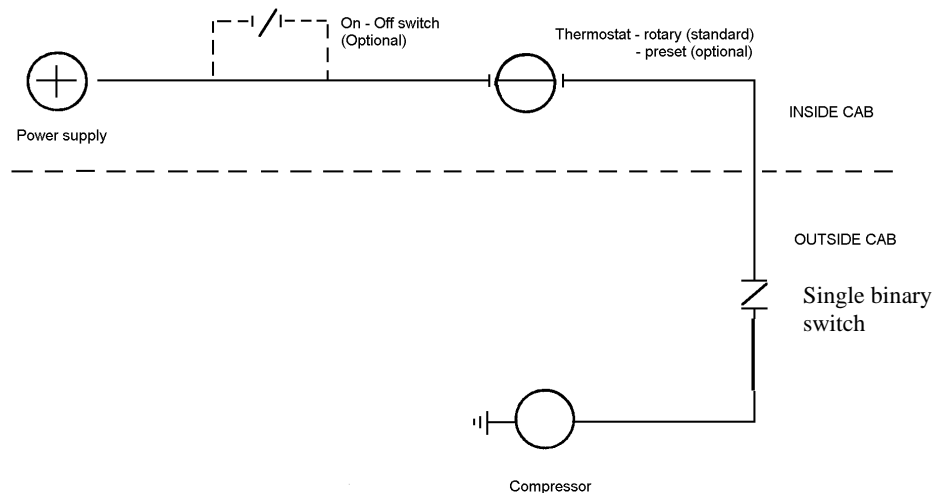

Thermostat location on panel.

## Refrigerant Flow Pattern in a Standard Air Conditioning System

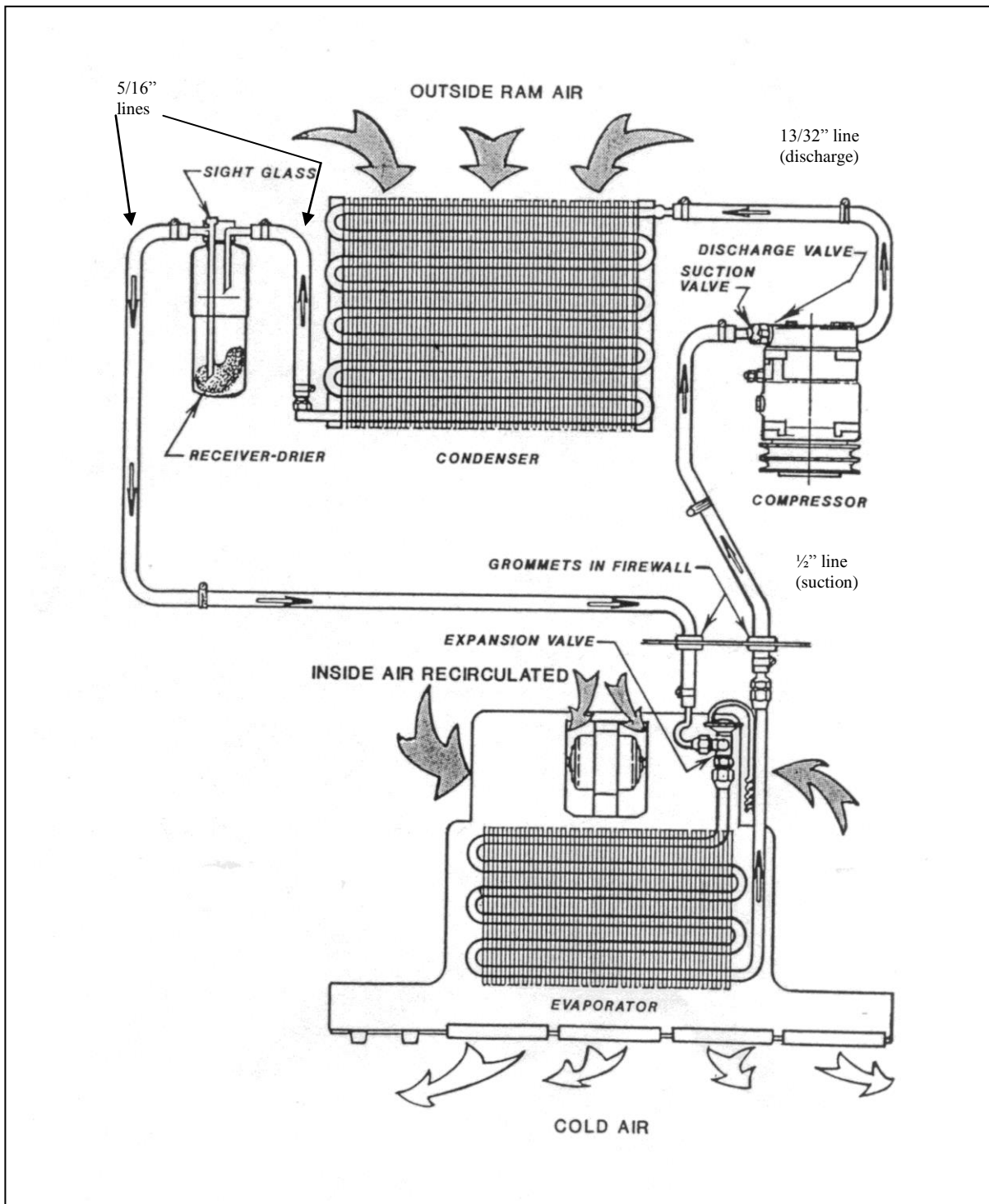

## Thermostat Setting Procedures

- 1) Thermostat types
  - a) preset
  - b) adjustable
    - a) A preset thermostat is adjusted to its specific cut in and cut out temperatures when manufactured and does not have a rotary adjustment for the operator.
    - b) An adjustable or rotary thermostat has been manufactured to a predetermined cut in and cut out temperatures, but it is also operator adjustable to achieve the desired comfort level.

Both types of thermostats can have their factory settings adjusted by turning the setting screws on the body of the thermostat. One body type has the setting screws mounted externally and labeled for direction of rotation. The other body type requires the removal of the plastic end plate to expose the set screw.

- 2) Thermostat probe location: The location of the thermostat probe in an evaporator coil can be very important to achieve the maximum cooling potential of the coil while also preventing coil freeze-up. There is no set location for the thermostat probe to be put that will be optimum for all systems, but several rules of thumb may be followed:
  - a) Insert the probe in the coldest area of the evaporator coil.
  - b) Insert the probe from the top of the coil down, if possible.
  - c) Make sure that at least the last 3" of the thermostat probe are in the coil.

To find the most likely area where the coil is the coldest, consider these factors:

- 1) Direction of air flow through the coil.
  - 2) The coil area likely to have the lowest air flow.
  - 3) The inlet locations of the refrigerant into the coil.
  - 4) The inlet of the hotter outside air into the coil area.
- 
- 1) Usually the coldest side of the evaporator coil will be the air outlet side. Often the thermostat probe can be inserted between the last and second last row of tubes.
  - 2) The lower air flow area of the evaporator coil in most systems tends to be near either end of the coil. These areas will be colder
  - 3) The area of the coil that the refrigerant inlet tube(s) occupy should be the coldest part of the coil.
  - 4) If the system is equipped with an outside air intake, where and how that air is brought into the evaporator area can have a large effect on the coil temperature. If all the outside air is piped into the evaporator in one area, that area will be considerably warmer in hot weather.

By looking at all these different factors, the area of an evaporator coil most likely to be the coldest can be determined.

Once the probe is inserted, the A/C system needs to be tested. Run the system to ensure that the thermostat is cycling the compressor off at the appropriate temperature. A core temperature ranging between 25° and 30° F should cause the thermostat to cycle off. The air temperature at the vent outlet closest to the evaporator coil should be between 38° F and 45° F when the compressor cycles off.

If the thermostat doesn't cycle off after a reasonable cool down period, and the air outlet temperature has dropped below 40° F, the cut in and cut out settings should be adjusted until the compressor is cycling on and off regularly. Let the system run for a decent time period (at least 15 min) and then check the evaporator coil for any signs of freezing.

## Aeroquip E-Z Clip Assembly Instructions

Step 1. Cut the hose to proper length with an appropriate cutting tool. Aeroquip's hand held hose cutter has been specially designed for cutting all non-wire reinforced hose, such as GH-134 Multi-Refrigerant hose. Be sure the cut is made square to the hose length.

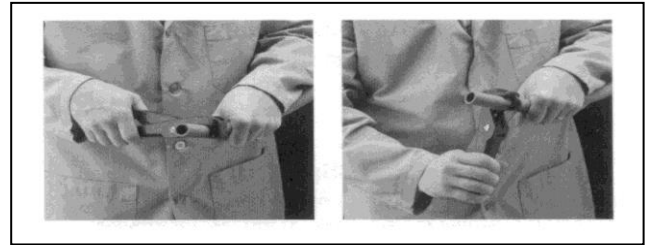

Step 2. Install two proper-sized clips onto the cut end of the hose. Orientation of the clips does not affect the performance of the connection. However, for ease of assembly, both clips should have the same orientation. NOTE: Failure to slide the clips over the hose at this time will require the clips to be stretched over the hose or fitting later. This may permanently damage the clip.

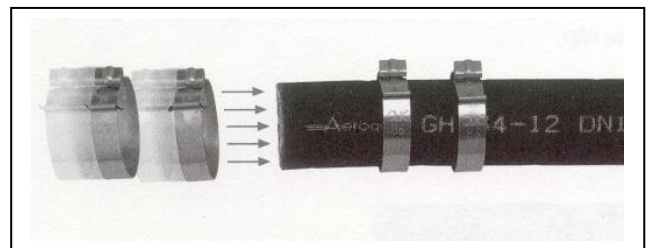

Step 3. Lubricate the nipple with a generous amount of the refrigeration or A/C system's compressor lubricating oil. This MUST be done to lower the force of nipple insertion.

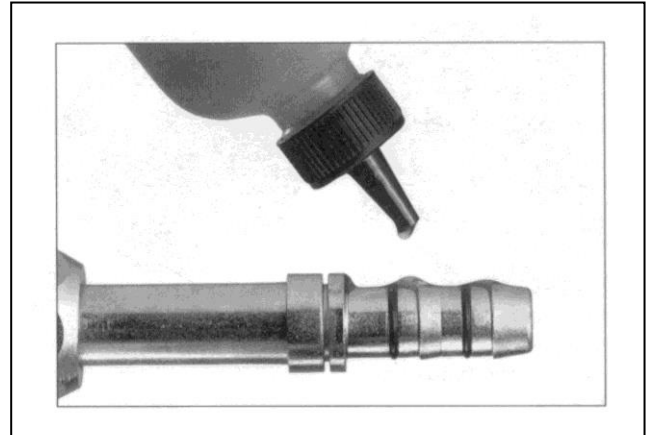

Step 4. Insert the nipple into the hose. To ensure that the nipple is fully inserted, check the gap between the cut end of the hose and the shoulder on the nipple. Care should be taken to avoid kinking or other damage to the hose during nipple insertion.

NOTE: Be sure to wipe excess oil from the nipple and hose.



Step 5. Snap the cage into the groove on the nipple. The arms should extend over the hose length. When the cage has been correctly installed in the cage groove, the cage will be able to rotate in the groove. This step **MUST** be performed to ensure:

1. The clips will be located over the O-rings on the nipple.
2. The connection will be compatible with the connection's pressure rating.

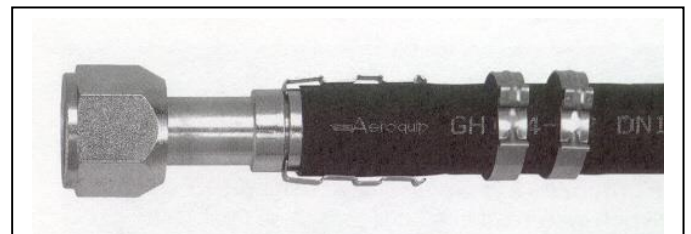
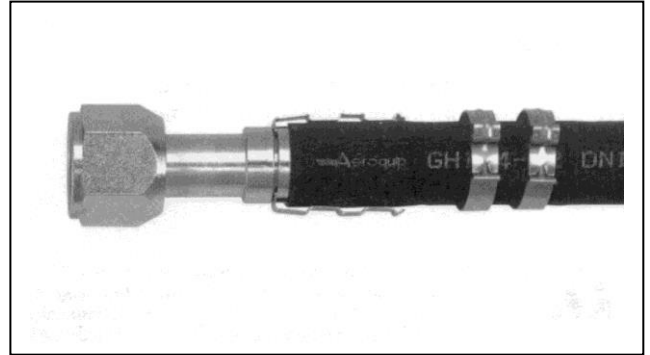

Step 6. Slide the clips over the cage arms and into the channels on each arm.

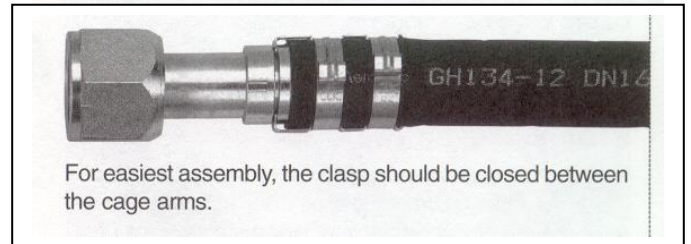

Step 7. Use the pliers to close the clips. The pliers should be positioned squarely on the clip connection points and should remain square during the closing of the clip.

**NOTICE:** E-Z Clip components should not be reused.

